

# 672/673

## SEMI-AUTOMATIC & AUTOMATIC BEDKNIFE GRINDERS



| FEATURES                                  | 672             | 673             |
|---|-----------------|-----------------|
| Mounting System                           | Electro Magnets | Electro Magnets |
| Adjustable Flood coolant                  | ✓               | ✓               |
| Quick retractable Setup Gauge             | ✓               | ✓               |
| Powered, Fixed Stop Grind Angle           | ✓               | ✓               |
| Integrated Diamond Dresser                | ✓               | ✓               |
| Height Adjustable Grinding head           | ✓               | ✓               |
| Variable Speed Belt Drive Traverse System | ✓               | ✓               |
| Automatic Mode - with Powered Infeed      |                 | ✓               |
| OPTIONAL EQUIPMENT                        |                 |                 |
| Borazon Wheel                             | Optional        | Optional        |
| Bellows Kit                               | Optional        | Optional        |
| Flood Coolant Additive                    | Optional        | Optional        |

WHEN ACCURACY AND SPEED MATTER, THESE GRINDERS DELIVER. SET-UP IS SIMPLE AND FAST WITH THE POSITIVE GAUGE STOPS.

### ► DIMENSIONS:

#### TOP VIEW

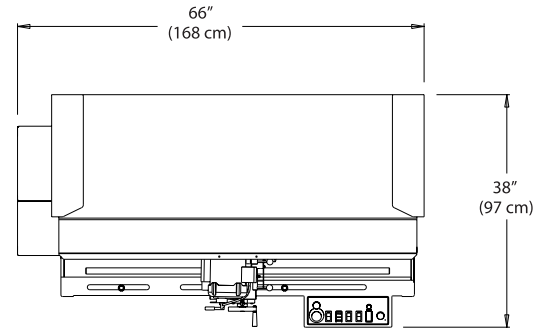

#### SIDE VIEW

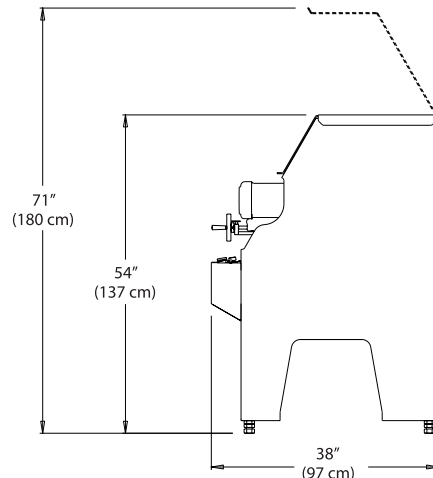

©2020 FOLEY COMPANY. ALL RIGHTS RESERVED. PNG3730172 - LU01072020

# 672/673 SEMI-AUTOMATIC & AUTOMATIC BEDKNIFE GRINDERS

ANGLE SET-UP



INTEGRATED FLOOD COOLANT



DIAMOND WHEEL DRESSER

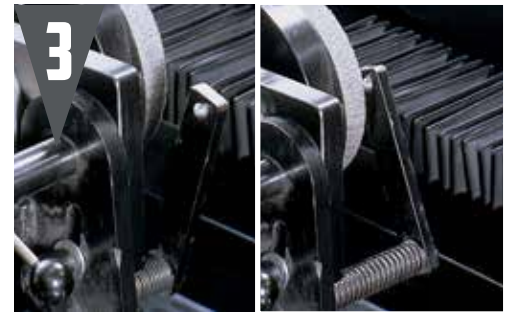

IN-FEED CONTROL



SUPPLEMENTAL POWER SUPPLY

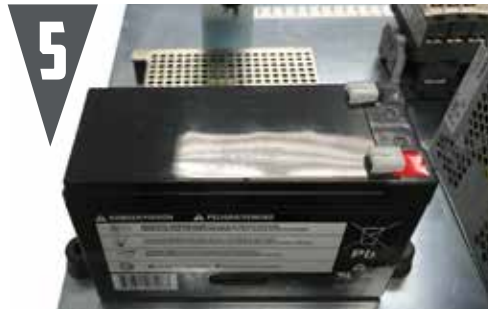

BELT DRIVE TRAVERSE SYSTEM



POWERED ANGLE ADJUSTMENT

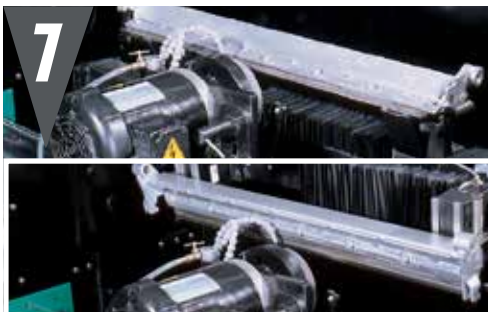

ELECTROMAGNETIC MOUNTING SYSTEM



ALIGNMENT GAUGE



## EASIEST + FASTEST TO USE BEDKNIFE GRINDERS IN THE WORLD

### AN INNOVATIVE BEDKNIFE MOUNTING SYSTEM

USES POWERFUL ELECTROMAGNETS TO HOLD THE BED BAR IN PLACE MAKING SET-UP SIMPLE AND FAST. YOU CAN GRIND ANY BED BAR ARRANGEMENT WITHOUT ADDITIONAL TOOLING.

### FAST ANGLE SET-UP

PROVIDES REPEATABILITY WITHOUT RECALIBRATION. CHANGING FROM GRINDING THE FRONT FACE TO THE TOP FACE IS AS SIMPLE AS PUSHING A BUTTON AND WATCHING AS THE POWERED TOOL BAR ROTATES INTO POSITION.

### EASY-TO-USE CONTROLS

USES A PRECISION HAND WHEEL TO IN-FEED THE GRINDING HEAD WHILE IT AUTOMATICALLY TRAVERSES. THE 673 AUTOMATES THE PROCESS BY USING ONE OF THE PRE-SET PROGRAMS TO AUTOMATICALLY IN-FEED THE GRINDING HEAD, AND STOP THE GRINDING PROCESS WHEN COMPLETED.

### OPERATOR PROTECTION

A STURDY METAL HOOD WITH A CLEAR POLYCARBONATE WINDOW THAT RETAINS THE COOLANT MIST AND SHIELDS THE OPERATOR. THE INTERLOCKING SWITCH PREVENTS OPERATION WITHOUT THE HOOD BEING TOTALLY CLOSED. THE SUPPLEMENTAL POWER SUPPLY PROTECTS THE OPERATOR IN THE EVENT OF A POWER OUTAGE, MAINTAINING POWER TO THE ELECTROMAGNETS AND HOLDING THE BED BAR FIRMLY IN PLACE.